

# 4SCU20LX

## PRODUCT SPECIFICATIONS

UP TO 20 SEER  
VARIABLE CAPACITY AIR CONDITIONER

FORM NO. 4SCU20LX-100 (03/2017)



**COMFORT SYNC**

COMMUNICATING THERMOSTAT ENABLED

### INSTALLED BY THE BEST

- Specialized training is required for dealers offering the 20LX
- Installer training available through authorized distributors

### COMPRESSOR

- Inverter-driven Scroll Compressor for true variable capacity operation, precision environmental control, and exceptional energy savings
- R410A refrigerant
- Heavy-duty compressor sound blanket for quiet operation
- Internally protected against high temperature motor overload conditions

### CABINET

- Individual metal louvered panels are easily removeable for coil cleaning and service
- Specialized corner-mounted controls for easy service
- Baked polyester paint finished over galvanized steel for maximum durability
- Removable PVC coated wire fan discharge grill
- Removable service panel for internal access

### COILS

- Enhanced tube-and-fin coil design featuring MHT™ Technology
- Raised coil prevents debris from impeding airflow

### DESIGN

- Designed to perform in temperatures up to 125°F

### COMPONENTS

- 45-degree offset gauge ports for easy service
- Service valves positioned for quick installation and service
- Variable speed condenser fan motor
- Swept wing fan blade for quiet operation
- Factory installed crankcase heater
- Factory installed high and low pressure switches
- Thread-on pressure switches for simple, quick service
- Fan orifice for smoother airflow and sound level reduction
- Specialized sensors monitor ambient, liquid line, and coil temperatures for precision system control
- Charged for 15 feet of line set
- Requires Comfort Sync™ thermostat and a Comfort Sync™ enabled matching indoor unit

### WARRANTY

- 10 year limited warranty on compressor
- 10 year limited warranty on all parts, extended warranty available

*\*Warranty provides for a total of 10 years of limited warranty coverage (Standard 5-year limited parts warranty plus an additional 5-year limited extended parts warranty). Warranty must be registered online within 60 days of installation to qualify for 10-year coverage. Unregistered equipment defaults to 5-year coverage. Lifetime limited heat exchanger warranty applies to registered equipment only (Standard 20 years with no online registration). See full warranty at [www.alliedair.com](http://www.alliedair.com) for terms, conditions and exclusions.*



**MODEL NUMBER GUIDE**

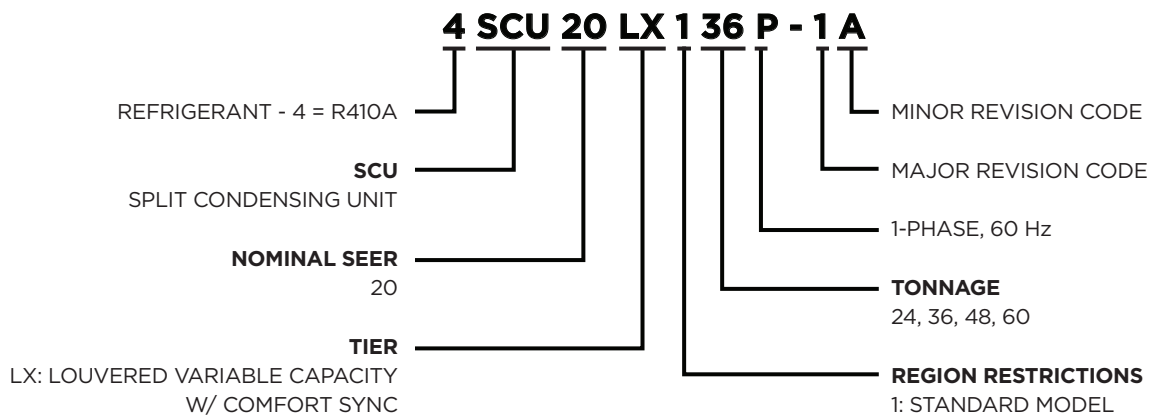

**ELECTRICAL AND PHYSICAL DATA**

Model	Voltage/Hz/ Phase	Voltage Range	Min. Circuit Amp.	Max. Over Current Device (amps)	Compressor		Outdoor Fan Motor			Weight (lbs.)
					Rated Load (amps)	Locked Rotor (amps)	Rated Load (amps)	Rated HP	Nom. RPM	
4SCU20LX124P-1	208-230/60/1	197-253	19.1	30	13.0	13	2.8	1/3	VAR. SPD.	243
4SCU20LX136P-1	208-230/60/1	197-253	20.6	30	14.2	13	2.8	1/3	VAR. SPD.	245
4SCU20LX148P-1	208-230/60/1	197-253	29.1	50	21.0	20	2.8	1/3	VAR. SPD.	287
4SCU20LX160P-1	208-230/60/1	197-253	29.3	50	21.2	20	2.8	1/3	VAR. SPD.	321

*Note:*  
Weights listed are unit weights with packaging

**DIMENSIONS (IN.) AND SOUND RATINGS**

Model No.	Dimensions (inch)			Sound Rating (dBA) low	Sound Rating (dBA) high
	A - Width	B - Depth	C - Height		
4SCU20LX124P-1	37.75	35.75	37.5	65	69
4SCU20LX136P-1	37.75	35.75	37.5	67	72
4SCU20LX148P-1	37.75	35.75	43.75	68	71
4SCU20LX160P-1	37.75	35.75	43.75	69	72

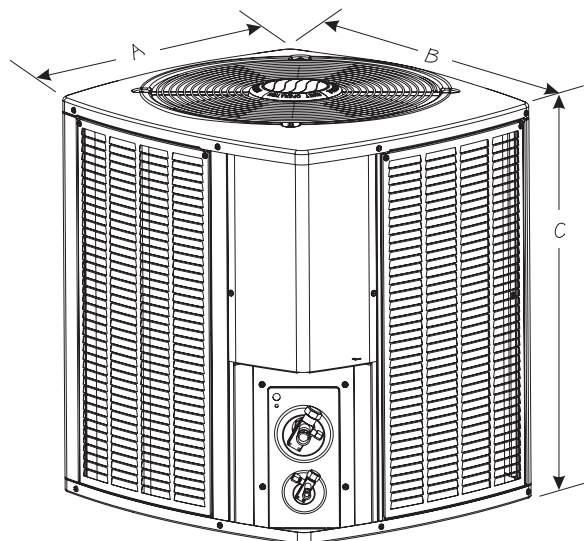

**REFRIGERATION DATA**

Model	Refrig. Charge (oz.) *	TXV	Refrigerant Line Size		Outdoor Unit Connection		Indoor Unit Connection	
			Suction	Liquid	Suction	Liquid	Suction	Liquid
4SCU20LX124P-1	113	H4TXV01	3/4	3/8	3/4	3/8	3/4	3/8
4SCU20LX136P-1	134	H4TXV02	7/8	3/8	7/8	3/8	7/8	3/8
4SCU20LX148P-1	154	H4TXV03	7/8	3/8	7/8	3/8	7/8	3/8
4SCU20LX160P-1	207	H4TXV03	1 1/8	3/8	7/8 **	3/8	7/8	3/8

\* Factory charged for 15 feet of line set; adjust per installation instructions.  
 \*\* Reducer fitting supplied with OD unit

**COOLING PERFORMANCE WITH AIR HANDLERS AND FURNACES**

Outdoor Model	Furnace	Evaporator Coil or Air Handler <sup>3</sup>	SEER	EER	AHRI Rated Capacity <sup>1</sup> BTUH	Sensible Rated Capacity	CFM High	CFM Med	CFM Low
4SCU20LX124P-1		BCE4M30S*	20.00	14.00	24,000	18,000	800	500	375
		BCE4M36S*	20.00	14.50	24,000	18,000	800	500	375
	A80DS2V090B16	E*1P48B+H4TXV01	20.00	14.00	24,000	18,000	800	500	375
	A80US2V070A12	E*1P29A+H4TXV01	20.00	14.00	24,000	18,000	800	500	375
	A80US2V070A12	E*1P36A+H4TXV01	20.00	14.50	24,000	18,000	800	500	375
	A80US2V090B12	E*1P29B+H4TXV01	20.00	14.00	24,000	18,000	800	500	375
	A80US2V090B12	E*1P36B+H4TXV01	20.00	14.50	24,000	18,000	800	500	375
	A96DS2V045B12	E*1P48B+H4TXV01	20.00	14.00	24,000	18,000	800	500	375
	A96DS2V070B16	E*1P48B+H4TXV01	20.00	14.00	24,000	18,000	800	500	375
	A96US2V045B12	E*1P29B+H4TXV01	20.00	14.00	24,000	18,000	800	500	375
	A96US2V045B12	E*1P36B+H4TXV01	20.00	14.50	24,000	18,000	800	500	375
	A96US2V070B12	E*1P29B+H4TXV01	20.00	14.00	24,000	18,000	800	500	375
	A96US2V070B12	E*1P36B+H4TXV01	20.00	14.50	24,000	18,000	800	500	375
	A97DSMV070B12	E*1P48B+H4TXV01	20.00	14.00	24,000	18,000	800	500	375
	A97USMV070B12	E*1P29B+H4TXV01	20.00	14.00	24,000	18,000	800	500	375
	A97USMV070B12	E*1P36B+H4TXV01	20.00	14.50	24,000	18,000	800	500	375
A97USMV090C12	E*1P36C+H4TXV01	20.00	14.00	24,000	18,000	800	500	375	

Note:

1. Certified in accordance with Unitary Air Conditioner Certification Program, which is based on AHRI Standard 210/240
2. Required to achieve AHRI rating. If NA (Not Applicable) is in the piston column, then TXV is required.
3. A blower time delay relay is standard on all Allied Air Enterprises furnace and AH products.

**COOLING PERFORMANCE WITH AIR HANDLERS AND FURNACES**

Outdoor Model	Furnace	Evaporator Coil or Air Handler <sup>2</sup>	SEER	EER	AHRI Rated Capacity <sup>1</sup> BTUH	Sensible Rated Capacity	CFM High	CFM Med	CFM Low
<b>4SCU20LX136P-1</b>		BCE4M36S*	20.00	13.00	34,400	25,500	1250	720	550
	A80DS2V090B16	E*1P48B+H4TXV02	20.00	13.50	34,800	25,500	1250	720	550
	A80US2V070A12	E*1P36A+H4TXV02	19.50	13.00	33,400	25,500	1250	720	550
	A80US2V090B12	E*1P36B+H4TXV02	20.00	13.50	35,000	25,500	1250	720	550
	A80US2V090B12	E*1P43B+H4TXV02	20.00	14.00	35,000	25,500	1250	720	550
	A80US2V090B12	E*1P48B+H4TXV02	20.00	13.50	34,800	25,500	1250	720	550
	A80US2V090B16	E*1P36B+H4TXV02	20.00	13.50	35,000	25,500	1250	720	550
	A80US2V090B16	E*1P43B+H4TXV02	20.00	14.00	35,000	25,500	1250	720	550
	A80US2V090B16	E*1P48B+H4TXV02	20.00	13.50	34,800	25,500	1250	720	550
	A96DS2V045B12	E*1P48B+H4TXV02	20.00	13.00	34,600	25,500	1250	720	550
	A96DS2V070B16	E*1P48B+H4TXV02	20.00	13.00	35,000	25,500	1250	720	550
	A96US2V045B12	E*1P36B+H4TXV02	20.00	13.00	34,800	25,500	1250	720	550
	A96US2V045B12	E*1P43B+H4TXV02	20.00	13.00	35,000	25,500	1250	720	550
	A96US2V045B12	E*1P48B+H4TXV02	20.00	13.00	34,600	25,500	1250	720	550
	A96US2V070B12	E*1P36B+H4TXV02	20.00	13.00	35,000	25,500	1250	720	550
	A96US2V070B12	E*1P43B+H4TXV02	20.00	13.00	35,000	25,500	1250	720	550
	A96US2V070B12	E*1P48B+H4TXV02	20.00	13.00	34,600	25,500	1250	720	550
	A96US2V090C12	E*1P43C+H4TXV02	20.00	13.50	35,000	25,500	1250	720	550
	A96US2V090C12	E*1P48C+H4TXV02	20.00	13.50	34,800	25,500	1250	720	550
	A96US2V090C12	E*1P50C+H4TXV02	20.00	13.50	35,000	25,500	1250	720	550
	A96US2V090C16	E*1P43C+H4TXV02	20.00	14.00	35,000	25,500	1250	720	550
	A96US2V090C16	E*1P48C+H4TXV02	20.00	13.50	34,800	25,500	1250	720	550
	A96US2V090C16	E*1P50C+H4TXV02	20.00	13.50	35,000	25,500	1250	720	550
	A96US2V110C16	E*1P43C+H4TXV02	20.00	14.00	35,000	25,500	1250	720	550
	A96US2V110C20	E*1P43C+H4TXV02	20.00	13.50	34,800	25,500	1250	720	550
	A97DSMV070B12	E*1P48B+H4TXV02	20.00	13.00	34,000	25,500	1250	720	550
	A97DSMV090C12	E*1P48C+H4TXV02	20.00	13.00	34,000	25,500	1250	720	550
	A97DSMV090C16	E*1P48C+H4TXV02	20.00	13.00	34,000	25,500	1250	720	550
	A97USMV070B12	E*1P36B+H4TXV02	20.00	13.00	35,000	25,500	1250	720	550
	A97USMV070B12	E*1P43B+H4TXV02	20.00	13.50	35,000	25,500	1250	720	550
	A97USMV070B12	E*1P48B+H4TXV02	20.00	13.00	34,600	25,500	1250	720	550
	A97USMV090C12	E*1P36C+H4TXV02	20.00	13.00	33,000	25,500	1250	720	550
	A97USMV090C12	E*1P43C+H4TXV02	20.00	13.50	35,000	25,500	1250	720	550
	A97USMV090C12	E*1P48C+H4TXV02	20.00	13.50	34,800	25,500	1250	720	550
	A97USMV090C12	E*1P50C+H4TXV02	20.00	13.50	35,000	25,500	1250	720	550
	A97USMV090C16	E*1P43C+H4TXV02	20.00	14.00	35,000	25,500	1250	720	550
	A97USMV090C16	E*1P48C+H4TXV02	20.00	13.50	34,800	25,500	1250	720	550
	A97USMV090C16	E*1P50C+H4TXV02	20.00	13.50	35,000	25,500	1250	720	550
	A97USMV110C20	E*1P43C+H4TXV02	20.00	14.00	35,000	25,500	1250	720	550
	A97USMV110C20	E*1P48C+H4TXV02	20.00	13.50	34,800	25,500	1250	720	550

Note:

1. Certified in accordance with Unitary Air Conditioner Certification Program, which is based on AHRI Standard 210/240
2. Required to achieve AHRI rating. If NA (Not Applicable) is in the piston column, then TXV is required.
3. A blower time delay relay is standard on all Allied Air Enterprises furnace and AH products.

**COOLING PERFORMANCE WITH AIR HANDLERS AND FURNACES**

Outdoor Model	Furnace	Evaporator Coil or Air Handler <sup>3</sup>	SEER	EER	AHRI Rated Capacity <sup>1</sup> BTUH	Sensible Rated Capacity	CFM High	CFM Med	CFM Low
4SCU20LX148P-1		BCE4M48S*	20.00	13.00	46,000	33,500	1580	1050	830
		BCE4M60S*	20.00	13.00	46,500	33,500	1580	1050	830
	A80DS2V110C20	E*1P50C+H4TXV03	19.00	12.00	46,000	33,500	1580	1050	830
	A80US2V090B16	E*1P43B+H4TXV03	19.00	12.00	45,500	33,500	1580	1050	830
	A80US2V090B16	E*1P48B+H4TXV03	19.00	12.00	45,000	33,500	1580	1050	830
	A80US2V090C20	E*1P43C+H4TXV03	19.00	12.00	46,000	33,500	1580	1050	830
	A80US2V090C20	E*1P49C+H4TXV03	19.00	12.00	46,500	33,500	1580	1050	830
	A80US2V090C20	E*1P50C+H4TXV03	19.00	12.00	45,500	33,500	1580	1050	830
	A80US2V090C20	E*1P48C+H4TXV03	18.50	12.00	45,000	33,500	1580	1050	830
	A80US2V110C20	E*1P43C+H4TXV03	19.00	12.00	46,000	33,500	1580	1050	830
	A80US2V110C20	E*1P48C+H4TXV03	19.00	12.00	45,000	33,500	1580	1050	830
	A80US2V110C20	E*1P50C+H4TXV03	19.00	12.00	45,500	33,500	1580	1050	830
	A96DS2V090C20	E*1P50C+H4TXV03	19.00	12.00	46,000	33,500	1580	1050	830
	A96DS2V110C20	E*1P50C+H4TXV03	19.00	12.00	46,000	33,500	1580	1050	830
	A96US2V090C16	E*1P43C+H4TXV03	19.00	12.00	45,500	33,500	1580	1050	830
	A96US2V090C16	E*1P48C+H4TXV03	19.00	12.00	45,000	33,500	1580	1050	830
	A96US2V090C16	E*1P49C+H4TXV03	19.00	12.00	46,000	33,500	1580	1050	830
	A96US2V090C16	E*1P50C+H4TXV03	19.00	12.00	46,000	33,500	1580	1050	830
	A96US2V090C20	E*1P48C+H4TXV03	19.00	12.00	45,000	33,500	1580	1050	830
	A96US2V090C20	E*1P49C+H4TXV03	19.00	12.00	46,000	33,500	1580	1050	830
	A96US2V090C20	E*1P50C+H4TXV03	19.00	12.00	46,000	33,500	1580	1050	830
	A96US2V110C16	E*1P43C+H4TXV03	19.00	12.00	46,000	33,500	1580	1050	830
	A96US2V110C16	E*1P49C+H4TXV03	19.00	12.00	46,000	33,500	1580	1050	830
	A96US2V110C16	E*1P50C+H4TXV03	19.00	12.00	45,500	33,500	1580	1050	830
	A96US2V110C16	E*1P48C+H4TXV03	18.50	12.00	45,000	33,500	1580	1050	830
	A96US2V110C20	E*1P49C+H4TXV03	19.00	12.00	46,000	33,500	1580	1050	830
	A96US2V110C20	E*1P50C+H4TXV03	19.00	12.00	46,000	33,500	1580	1050	830
	A96US2V110C20	E*1P48C+H4TXV03	18.50	12.00	45,000	33,500	1580	1050	830
	A97DSMV090C16	E*1P50C+H4TXV03	19.00	12.00	46,000	33,500	1580	1050	830
	A97DSMV090C20	E*1P50C+H4TXV03	19.00	12.00	46,000	33,500	1580	1050	830
	A97DSMV110C20	E*1P50C+H4TXV03	19.00	12.00	46,000	33,500	1580	1050	830
	A97USMV090C16	E*1P43C+H4TXV03	19.00	12.00	46,000	33,500	1580	1050	830
	A97USMV090C16	E*1P48C+H4TXV03	19.00	12.00	45,000	33,500	1580	1050	830
	A97USMV090C16	E*1P49C+H4TXV03	19.00	12.00	46,500	33,500	1580	1050	830
	A97USMV090C16	E*1P50C+H4TXV03	19.00	12.00	45,500	33,500	1580	1050	830
	A97USMV090C20	E*1P43C+H4TXV03	19.00	12.00	46,000	33,500	1580	1050	830
	A97USMV090C20	E*1P49C+H4TXV03	19.00	12.00	46,500	33,500	1580	1050	830
	A97USMV090C20	E*1P50C+H4TXV03	19.00	12.00	45,500	33,500	1580	1050	830
	A97USMV090C20	E*1P48C+H4TXV03	18.50	12.00	45,000	33,500	1580	1050	830
	A97USMV110C20	E*1P43C+H4TXV03	19.00	12.00	46,000	33,500	1580	1050	830
	A97USMV110C20	E*1P48C+H4TXV03	19.00	12.00	46,500	33,500	1580	1050	830
	A97USMV110C20	E*1P49C+H4TXV03	19.00	12.00	46,500	33,500	1580	1050	830
A97USMV110C20	E*1P50C+H4TXV03	19.00	12.00	45,500	33,500	1580	1050	830	

Note:

1. Certified in accordance with Unitary Air Conditioner Certification Program, which is based on AHRI Standard 210/240
2. Required to achieve AHRI rating. If NA (Not Applicable) is in the piston column, then TXV is required.
3. A blower time delay relay is standard on all Allied Air Enterprises furnace and AH products.

**COOLING PERFORMANCE WITH AIR HANDLERS AND FURNACES**

Outdoor Model	Furnace	Evaporator Coil or Air Handler <sup>2</sup>	SEER	EER	AHRI Rated Capacity <sup>1</sup> BTUH	Sensible Rated Capacity	CFM High	CFM Med	CFM Low
<b>4SCU20LX160P</b>		BCE4M60S*	19.00	13.00	57,000	41,500	1800	1135	890
	A80US2V090C20	E*1P49C+H4TXV03	19.00	13.00	57,000	41,500	1800	1135	890
	A80US2V090C20	E*1P62C+H4TXV03.	19.00	13.00	58,000	41,500	1800	1135	890
	A80US2V110C20	E*1P49C+H4TXV03	19.00	12.50	57,000	41,500	1800	1135	890
	A80US2V110C20	E*1P62C+H4TXV03.	19.00	13.00	58,000	41,500	1800	1135	890
	A80US2V135D20	E*1P62D+H4TXV03	19.00	13.00	57,000	41,500	1800	1135	890
	A96US2V090C20	E*1P49C+H4TXV03	19.00	12.50	56,500	41,500	1800	1135	890
	A96US2V090C20	E*1P62C+H4TXV03.	19.00	12.50	57,000	41,500	1800	1135	890
	A96US2V110C20	E*1P49C+H4TXV03	19.00	12.50	56,500	41,500	1800	1135	890
	A96US2V110C20	E*1P62C+H4TXV03.	19.00	12.50	57,000	41,500	1800	1135	890
	A96US2V135D20	E*1P62D+H4TXV03	19.00	12.50	57,000	41,500	1800	1135	890
	A97USMV090C20	E*1P49C+H4TXV03	19.00	12.50	56,500	41,500	1800	1135	890
	A97USMV090C20	E*1P62C+H4TXV03.	19.00	12.70	58,000	41,500	1800	1135	890
	A97USMV110C20	E*1P49C+H4TXV03	19.00	12.50	56,500	41,500	1800	1135	890
	A97USMV110C20	E*1P62C+H4TXV03.	19.00	13.00	58,000	41,500	1800	1135	890
	A97USMV135D20	E*1P62D+H4TXV03	19.00	13.00	57,000	41,500	1800	1135	890

Note:

1. Certified in accordance with Unitary Air Conditioner Certification Program, which is based on AHRI Standard 210/240
2. Required to achieve AHRI rating. If NA (Not Applicable) is in the piston column, then TXV is required.
3. A blower time delay relay is standard on all Allied Air Enterprises furnace and AH products.

**COOLING PERFORMANCE EXTENDED RATINGS**

4SCU20LX124P-1 - BCE4M30S - (MAXIMUM CAPACITY)																					
Entering Wet Bulb Temperature	Total Air Volume	Outdoor Air Temperature Entering Outdoor Coil																			
		85°F					95°F					105°F					115°F				
		Total Cool Cap.	Comp Motor Input	Sensible to Total Ratio (S/T)			Total Cool Cap.	Comp Motor Input	Sensible to Total Ratio (S/T)			Total Cool Cap.	Comp Motor Input	Sensible to Total Ratio (S/T)			Total Cool Cap.	Comp Motor Input	Sensible to Total Ratio (S/T)		
				Dry Bulb					Dry Bulb					Dry Bulb					Dry Bulb		
		cfm	kBtuh	kW	75°F	80°F	85°F	kBtuh	kW	75°F	80°F	85°F	kBtuh	kW	75°F	80°F	85°F	kBtuh	kW	75°F	80°F
59°F	425	19.5	1.34	0.82	0.93	1	18.6	1.54	0.83	0.95	1	17.8	1.76	0.85	0.97	1	16.8	2.02	0.87	0.99	1
	800	23.8	1.3	0.98	1	1	23	1.5	1	1	1	21.8	1.72	1	1	1	20.6	1.98	1	1	1
	900	24.8	1.29	1	1	1	23.6	1.49	1	1	1	22.6	1.71	1	1	1	21.2	1.97	1	1	1
63°F	425	20.8	1.33	0.68	0.78	0.89	19.8	1.52	0.69	0.8	0.9	18.9	1.75	0.7	0.81	0.93	17.8	2.01	0.71	0.83	0.95
	800	24.2	1.29	0.8	0.95	1	23.2	1.5	0.81	0.98	1	21.8	1.72	0.84	1	1	20.6	1.98	0.86	1	1
	900	24.8	1.29	0.83	0.99	1	23.8	1.49	0.84	1	1	22.6	1.71	0.87	1	1	21.4	1.97	0.91	1	1
67°F	425	22	1.32	0.55	0.65	0.75	21	1.51	0.55	0.66	0.76	20	1.74	0.56	0.67	0.78	18.9	2	0.57	0.68	0.8
	800	25.8	1.28	0.62	0.77	0.92	24.4	1.48	0.63	0.79	0.94	23.2	1.7	0.64	0.81	0.97	21.6	1.97	0.66	0.84	1
	900	26.2	1.27	0.64	0.8	0.96	25	1.47	0.65	0.82	0.98	23.6	1.7	0.66	0.85	1	22	1.96	0.69	0.88	1
71°F	425	23.2	1.3	0.43	0.53	0.62	22.2	1.51	0.43	0.54	0.63	21.2	1.73	0.43	0.54	0.64	19.9	1.99	0.44	0.55	0.66
	800	27.2	1.26	0.46	0.61	0.75	25.8	1.46	0.47	0.62	0.77	24.4	1.69	0.47	0.63	0.79	22.8	1.95	0.48	0.65	0.82
	900	27.6	1.25	0.47	0.63	0.78	26.4	1.46	0.47	0.64	0.8	24.8	1.68	0.48	0.65	0.82	23.2	1.95	0.49	0.68	0.86

4SCU20LX124P-1 - BCE4M30S - (INTERMEDIATE CAPACITY)																					
Entering Wet Bulb Temperature	Total Air Volume	Outdoor Air Temperature Entering Outdoor Coil																			
		75°F					85°F					95°F					105°F				
		Total	Comp	Sensible to Total			Total	Comp	Sensible to Total			Total	Comp	Sensible to Total			Total	Comp	Sensible to Total		
		Cool	Motor	Ratio (S/T)			Cool	Motor	Ratio (S/T)			Cool	Motor	Ratio (S/T)			Cool	Motor	Ratio (S/T)		
		Cap.	Input	Dry Bulb			Cap.	Input	Dry Bulb			Cap.	Input	Dry Bulb			Cap.	Input	Dry Bulb		
cfm	kBtuh	kW	75°F	80°F	85°F	kBtuh	kW	75°F	80°F	85°F	kBtuh	kW	75°F	80°F	85°F	kBtuh	kW	75°F	80°F	85°F	
59°F	260	11.5	0.58	0.83	0.94	1	11	0.69	0.84	0.96	1	10.5	0.79	0.86	0.98	1	10	0.91	0.88	1	1
	515	14.5	0.54	1	1	1	13.9	0.65	1	1	1	13.3	0.76	1	1	1	12.7	0.89	1	1	1
	570	14.9	0.54	1	1	1	14.3	0.65	1	1	1	13.7	0.75	1	1	1	13	0.88	1	1	1
63°F	260	12.2	0.57	0.68	0.79	0.9	11.7	0.68	0.69	0.8	0.92	11.2	0.78	0.7	0.82	0.94	10.6	0.9	0.71	0.84	0.96
	515	14.5	0.55	0.83	0.99	1	13.9	0.65	0.85	1	1	13.3	0.76	0.87	1	1	12.7	0.89	0.9	1	1
	570	14.9	0.54	0.86	1	1	14.3	0.65	0.88	1	1	13.7	0.75	0.9	1	1	13	0.88	0.94	1	1
67°F	260	12.9	0.56	0.55	0.65	0.76	12.4	0.67	0.56	0.66	0.77	11.9	0.77	0.56	0.67	0.79	11.3	0.9	0.57	0.69	0.8
	515	15.3	0.53	0.64	0.8	0.96	14.6	0.64	0.65	0.83	0.98	13.9	0.75	0.66	0.84	1	13.1	0.88	0.68	0.87	1
	570	15.6	0.53	0.66	0.84	1	14.9	0.64	0.66	0.86	1	14.1	0.75	0.69	0.88	1	13.4	0.88	0.71	0.91	1
71°F	260	13.7	0.56	0.43	0.53	0.63	13.1	0.66	0.43	0.54	0.64	12.6	0.77	0.43	0.54	0.65	11.9	0.89	0.44	0.55	0.66
	515	16.1	0.52	0.47	0.62	0.78	15.4	0.63	0.47	0.64	0.8	14.7	0.74	0.48	0.65	0.82	13.9	0.87	0.48	0.67	0.85
	570	16.4	0.52	0.48	0.65	0.81	15.7	0.63	0.48	0.66	0.83	14.9	0.74	0.48	0.67	0.86	14.1	0.87	0.49	0.7	0.89

4SCU20LX124P-1 - BCE4M30S - (MINIMUM CAPACITY)																					
Entering Wet Bulb Temperature	Total Air Volume	Outdoor Air Temperature Entering Outdoor Coil																			
		75°F					85°F					95°F					105°F				
		Total	Comp	Sensible to Total			Total	Comp	Sensible to Total			Total	Comp	Sensible to Total			Total	Comp	Sensible to Total		
		Cool	Motor	Ratio (S/T)			Cool	Motor	Ratio (S/T)			Cool	Motor	Ratio (S/T)			Cool	Motor	Ratio (S/T)		
		Cap.	Input	Dry Bulb			Cap.	Input	Dry Bulb			Cap.	Input	Dry Bulb			Cap.	Input	Dry Bulb		
cfm	kBtuh	kW	75°F	80°F	85°F	kBtuh	kW	75°F	80°F	85°F	kBtuh	kW	75°F	80°F	85°F	kBtuh	kW	75°F	80°F	85°F	
59°F	185	7.7	0.33	0.88	1	1	7.4	0.38	0.9	1	1	7.1	0.43	0.92	1	1	6.7	0.5	0.95	1	1
	375	9.9	0.29	1	1	1	9.4	0.34	1	1	1	9	0.4	1	1	1	8.5	0.48	1	1	1
	400	10	0.28	1	1	1	9.6	0.34	1	1	1	9.1	0.39	1	1	1	8.7	0.47	1	1	1
63°F	185	8.2	0.32	0.71	0.84	0.96	7.8	0.38	0.73	0.86	0.99	7.4	0.43	0.74	0.88	1	6.9	0.5	0.76	0.91	1
	375	9.9	0.29	0.91	1	1	9.4	0.34	0.94	1	1	9	0.4	0.97	1	1	8.5	0.48	1	1	1
	400	10	0.28	0.93	1	1	9.6	0.34	0.97	1	1	9.1	0.39	0.99	1	1	8.7	0.47	1	1	1
67°F	185	8.7	0.31	0.57	0.69	0.8	8.3	0.37	0.58	0.7	0.82	7.9	0.42	0.58	0.72	0.84	7.4	0.5	0.59	0.73	0.87
	375	10.2	0.28	0.68	0.89	1	9.6	0.34	0.7	0.91	1	9.1	0.39	0.72	0.94	1	8.6	0.48	0.75	0.98	1
	400	10.3	0.28	0.7	0.91	1	9.7	0.34	0.72	0.94	1	9.2	0.39	0.74	0.97	1	8.7	0.47	0.77	1	1
71°F	185	9.2	0.3	0.44	0.55	0.66	8.8	0.36	0.44	0.56	0.67	8.3	0.41	0.44	0.57	0.69	7.9	0.49	0.44	0.58	0.7
	375	10.7	0.27	0.49	0.67	0.86	10.2	0.33	0.49	0.69	0.89	9.7	0.38	0.5	0.71	0.92	9.1	0.47	0.51	0.73	0.95
	400	10.8	0.27	0.49	0.69	0.89	10.3	0.32	0.51	0.71	0.92	9.7	0.38	0.51	0.73	0.95	9.2	0.47	0.52	0.76	0.98

**COOLING PERFORMANCE EXTENDED RATINGS**

4SCU20LX136P-1 - BCE4M36S - (MAXIMUM CAPACITY)																					
Entering Wet Bulb Temperature	Total Air Volume	Outdoor Air Temperature Entering Outdoor Coil																			
		85°F					95°F					105°F					115°F				
		Total Cool Cap.	Comp Motor Input	Sensible to Total Ratio (S/T)			Total Cool Cap.	Comp Motor Input	Sensible to Total Ratio (S/T)			Total Cool Cap.	Comp Motor Input	Sensible to Total Ratio (S/T)			Total Cool Cap.	Comp Motor Input	Sensible to Total Ratio (S/T)		
				Dry Bulb					Dry Bulb					Dry Bulb					Dry Bulb		
cfm	kBtuh	kW	75°F	80°F	85°F	kBtuh	kW	75°F	80°F	85°F	kBtuh	kW	75°F	80°F	85°F	kBtuh	kW	75°F	80°F	85°F	
59°F	640	28.2	1.9	0.83	0.95	1	26.8	2.19	0.85	0.97	1	25.2	2.52	0.87	1	1	23.8	2.87	0.9	1	1
	1250	35	1.84	1	1	1	33.4	2.14	1	1	1	31.8	2.47	1	1	1	29.8	2.82	1	1	1
	1300	35.4	1.84	1	1	1	33.8	2.14	1	1	1	32.2	2.46	1	1	1	30.2	2.82	1	1	1
63°F	640	30	1.88	0.69	0.8	0.91	28.6	2.18	0.7	0.81	0.93	27	2.5	0.71	0.84	0.96	25	2.86	0.73	0.86	0.99
	1250	35.4	1.84	0.82	0.97	1	33.6	2.14	0.84	0.99	1	31.8	2.47	0.87	1	1	29.8	2.81	0.91	1	1
	1300	35.6	1.84	0.83	0.98	1	34	2.14	0.85	1	1	32.2	2.46	0.88	1	1	30.2	2.82	0.92	1	1
67°F	640	32	1.87	0.56	0.66	0.76	30.4	2.16	0.56	0.67	0.78	28.8	2.49	0.57	0.68	0.8	26.8	2.84	0.58	0.7	0.83
	1250	37.2	1.82	0.63	0.79	0.94	35.4	2.12	0.65	0.81	0.97	33.4	2.45	0.66	0.84	0.99	31	2.8	0.68	0.88	1
	1300	37.6	1.82	0.64	0.8	0.95	35.6	2.12	0.65	0.83	0.98	33.6	2.45	0.67	0.85	1	31.2	2.8	0.69	0.89	1
71°F	640	33.6	1.86	0.43	0.54	0.63	32.2	2.15	0.44	0.54	0.64	30.6	2.48	0.44	0.55	0.66	28.6	2.83	0.44	0.56	0.67
	1250	39	1.81	0.47	0.61	0.77	37.4	2.11	0.47	0.63	0.79	35.4	2.43	0.48	0.65	0.81	33	2.78	0.49	0.67	0.85
	1300	39	1.81	0.47	0.63	0.78	37.6	2.11	0.48	0.64	0.8	35.6	2.43	0.48	0.66	0.83	33.2	2.79	0.49	0.68	0.86

4SCU20LX136P-1 - BCE4M36S - (INTERMEDIATE CAPACITY)																					
Entering Wet Bulb Temperature	Total Air Volume	Outdoor Air Temperature Entering Outdoor Coil																			
		75°F					85°F					95°F					105°F				
		Total	Comp	Sensible to Total			Total	Comp	Sensible to Total			Total	Comp	Sensible to Total			Total	Comp	Sensible to Total		
		Cool	Motor	Ratio (S/T)			Cool	Motor	Ratio (S/T)			Cool	Motor	Ratio (S/T)			Cool	Motor	Ratio (S/T)		
		Cap.	Input	Dry Bulb			Cap.	Input	Dry Bulb			Cap.	Input	Dry Bulb			Cap.	Input	Dry Bulb		
cfm	kBtuh	kW	75°F	80°F	85°F	kBtuh	kW	75°F	80°F	85°F	kBtuh	kW	75°F	80°F	85°F	kBtuh	kW	75°F	80°F	85°F	
59°F	400	17.2	0.78	0.85	0.98	1	16.3	0.94	0.87	1	1	15.5	1.11	0.9	1	1	14.6	1.29	0.93	1	1
	750	21.6	0.72	1	1	1	20.6	0.88	1	1	1	19.5	1.05	1	1	1	18.3	1.24	1	1	1
	800	22	0.71	1	1	1	21	0.88	1	1	1	19.8	1.05	1	1	1	18.7	1.23	1	1	1
63°F	400	18.4	0.77	0.7	0.81	0.93	17.4	0.93	0.71	0.83	0.95	16.4	1.1	0.72	0.86	0.98	15.4	1.29	0.74	0.88	1
	750	21.6	0.72	0.83	0.99	1	20.6	0.88	0.86	1	1	19.4	1.05	0.89	1	1	18.4	1.24	0.93	1	1
	800	22	0.71	0.85	1	1	21	0.88	0.88	1	1	19.9	1.05	0.91	1	1	18.7	1.23	0.95	1	1
67°F	400	19.6	0.75	0.56	0.67	0.78	18.6	0.91	0.57	0.68	0.79	17.6	1.09	0.57	0.7	0.82	16.5	1.27	0.58	0.71	0.84
	750	22.8	0.7	0.64	0.8	0.96	21.6	0.87	0.66	0.83	0.99	20.4	1.04	0.67	0.86	1	18.9	1.22	0.69	0.9	1
	800	23.2	0.69	0.65	0.82	0.98	22	0.86	0.67	0.85	1	20.6	1.03	0.69	0.89	1	19.2	1.22	0.71	0.92	1
71°F	400	20.8	0.73	0.44	0.54	0.64	19.8	0.9	0.44	0.55	0.65	18.7	1.07	0.44	0.56	0.67	17.6	1.25	0.44	0.57	0.69
	750	24	0.68	0.46	0.63	0.78	22.8	0.84	0.47	0.64	0.81	21.6	1.02	0.48	0.66	0.83	20.2	1.2	0.49	0.68	0.87
	800	24.2	0.67	0.47	0.64	0.79	23.2	0.84	0.48	0.66	0.82	21.8	1.01	0.49	0.67	0.86	20.6	1.2	0.5	0.7	0.89

4SCU20LX136P-1 - BCE4M36S - (MINIMUM CAPACITY)																					
Entering Wet Bulb Temperature	Total Air Volume	Outdoor Air Temperature Entering Outdoor Coil																			
		75°F					85°F					95°F					105°F				
		Total	Comp	Sensible to Total			Total	Comp	Sensible to Total			Total	Comp	Sensible to Total			Total	Comp	Sensible to Total		
		Cool	Motor	Ratio (S/T)			Cool	Motor	Ratio (S/T)			Cool	Motor	Ratio (S/T)			Cool	Motor	Ratio (S/T)		
		Cap.	Input	Dry Bulb			Cap.	Input	Dry Bulb			Cap.	Input	Dry Bulb			Cap.	Input	Dry Bulb		
cfm	kBtuh	kW	75°F	80°F	85°F	kBtuh	kW	75°F	80°F	85°F	kBtuh	kW	75°F	80°F	85°F	kBtuh	kW	75°F	80°F	85°F	
59°F	250	10	0.43	0.87	1	1	9.2	0.53	0.91	1	1	8.6	0.64	0.95	1	1	8.1	0.77	0.99	1	1
	550	13.3	0.34	1	1	1	12.2	0.44	1	1	1	11.3	0.56	1	1	1	10.5	0.71	1	1	1
	550	13.3	0.34	1	1	1	12.2	0.44	1	1	1	11.3	0.56	1	1	1	10.5	0.71	1	1	1
63°F	250	10.6	0.41	0.71	0.83	0.95	9.7	0.51	0.73	0.87	0.99	8.9	0.63	0.76	0.9	1	8.2	0.77	0.79	0.94	1
	550	13.3	0.34	0.92	1	1	12.2	0.45	0.97	1	1	11.3	0.57	1	1	1	10.5	0.7	1	1	1
	550	13.3	0.34	0.92	1	1	12.2	0.45	0.97	1	1	11.3	0.57	1	1	1	10.5	0.7	1	1	1
67°F	250	11.4	0.4	0.57	0.68	0.79	10.4	0.5	0.58	0.7	0.83	9.6	0.61	0.59	0.73	0.86	8.8	0.75	0.61	0.76	0.9
	550	13.7	0.33	0.69	0.9	1	12.5	0.44	0.72	0.95	1	11.4	0.56	0.76	0.99	1	10.5	0.71	0.8	1	1
	550	13.7	0.33	0.69	0.9	1	12.5	0.44	0.72	0.95	1	11.4	0.56	0.76	0.99	1	10.5	0.71	0.8	1	1
71°F	250	12.1	0.38	0.43	0.55	0.65	11.1	0.48	0.44	0.56	0.67	10.2	0.6	0.44	0.57	0.7	9.5	0.74	0.45	0.59	0.73
	550	14.5	0.31	0.48	0.68	0.87	13.3	0.41	0.5	0.72	0.92	12.1	0.54	0.52	0.75	0.97	11.2	0.69	0.53	0.79	1
	550	14.5	0.31	0.48	0.68	0.87	13.3	0.41	0.5	0.72	0.92	12.1	0.54	0.52	0.75	0.97	11.2	0.69	0.53	0.79	1



**COOLING PERFORMANCE EXTENDED RATINGS**

4SCU20LX148P-1 - BCE4M48S - (MAXIMUM CAPACITY)																					
Entering Wet Bulb Temperature	Total Air Volume	Outdoor Air Temperature Entering Outdoor Coil																			
		85°F					95°F					105°F					115°F				
		Total Cool Cap.	Comp Motor Input	Sensible to Total Ratio (S/T)			Total Cool Cap.	Comp Motor Input	Sensible to Total Ratio (S/T)			Total Cool Cap.	Comp Motor Input	Sensible to Total Ratio (S/T)			Total Cool Cap.	Comp Motor Input	Sensible to Total Ratio (S/T)		
				Dry Bulb					Dry Bulb					Dry Bulb					Dry Bulb		
		cfm	kBtuh	kW	75°F	80°F	85°F	kBtuh	kW	75°F	80°F	85°F	kBtuh	kW	75°F	80°F	85°F	kBtuh	kW	75°F	80°F
59°F	900	39	2.65	0.84	0.95	1	37.6	2.99	0.85	0.97	1	35.8	3.38	0.87	0.99	1	33.6	3.79	0.9	1	1
	1580	46.5	2.66	0.99	1	1	44.5	3.01	1	1	1	42.5	3.4	1	1	1	40	3.83	1	1	1
	1725	47.5	2.65	1	1	1	45.5	3.01	1	1	1	43.5	3.4	1	1	1	40.5	3.82	1	1	1
63°F	900	41.5	2.65	0.69	0.8	0.91	40	3	0.7	0.82	0.93	38	3.39	0.71	0.83	0.95	35.2	3.8	0.73	0.86	0.98
	1580	47	2.65	0.8	0.96	1	45	3.01	0.82	0.98	1	43	3.4	0.84	1	1	40	3.83	0.87	1	1
	1725	48	2.65	0.82	0.98	1	46	3.01	0.84	1	1	43.5	3.4	0.87	1	1	41	3.83	0.9	1	1
67°F	900	44	2.65	0.56	0.67	0.77	42	3.01	0.56	0.68	0.78	40	3.4	0.57	0.69	0.8	37.4	3.81	0.58	0.7	0.83
	1580	49.5	2.65	0.62	0.78	0.93	47.5	3.01	0.63	0.8	0.95	45	3.4	0.65	0.82	0.98	41.5	3.83	0.67	0.85	1
	1725	50.5	2.65	0.64	0.8	0.96	48	3.01	0.65	0.82	0.98	45.5	3.4	0.66	0.85	1	42	3.82	0.69	0.88	1
71°F	900	46	2.65	0.43	0.54	0.64	44.5	3.01	0.44	0.55	0.65	42	3.39	0.43	0.55	0.66	39.5	3.83	0.44	0.56	0.68
	1580	52	2.65	0.46	0.61	0.76	50	3.01	0.47	0.62	0.77	47	3.4	0.47	0.64	0.8	43.5	3.83	0.48	0.66	0.83
	1725	53	2.65	0.47	0.63	0.78	50.5	3.01	0.47	0.64	0.8	48	3.4	0.48	0.66	0.82	44	3.83	0.49	0.68	0.86

4SCU20LX148P-1 - BCE4M48S - (INTERMEDIATE CAPACITY)																					
Entering Wet Bulb Temperature	Total Air Volume	Outdoor Air Temperature Entering Outdoor Coil																			
		75°F					85°F					95°F					105°F				
		Total Cool Cap.	Comp Motor Input	Sensible to Total Ratio (S/T)			Total Cool Cap.	Comp Motor Input	Sensible to Total Ratio (S/T)			Total Cool Cap.	Comp Motor Input	Sensible to Total Ratio (S/T)			Total Cool Cap.	Comp Motor Input	Sensible to Total Ratio (S/T)		
				Dry Bulb					Dry Bulb					Dry Bulb					Dry Bulb		
		cfm	kBtuh	kW	75°F	80°F	85°F	kBtuh	kW	75°F	80°F	85°F	kBtuh	kW	75°F	80°F	85°F	kBtuh	kW	75°F	80°F
59°F	550	25.2	1.26	0.82	0.94	1	24.2	1.49	0.84	0.95	1	23	1.74	0.85	0.97	1	22	2.01	0.87	0.99	1
	1050	31	1.22	1	1	1	29.8	1.46	1	1	1	28.6	1.71	1	1	1	27.2	1.99	1	1	1
	1150	31.8	1.21	1	1	1	30.6	1.45	1	1	1	29.4	1.71	1	1	1	28	1.99	1	1	1
63°F	550	26.8	1.25	0.68	0.79	0.9	25.6	1.48	0.69	0.8	0.91	24.6	1.73	0.7	0.82	0.93	23.4	2	0.71	0.83	0.95
	1050	31.2	1.21	0.8	0.97	1	30	1.46	0.83	0.99	1	28.6	1.72	0.85	1	1	27.4	1.99	0.88	1	1
	1150	32	1.21	0.83	1	1	30.6	1.46	0.85	1	1	29.4	1.71	0.88	1	1	28	1.99	0.91	1	1
67°F	550	28.4	1.24	0.55	0.65	0.75	27.2	1.48	0.56	0.66	0.77	26	1.73	0.56	0.67	0.78	24.8	2	0.57	0.68	0.8
	1050	33	1.2	0.63	0.78	0.94	31.6	1.45	0.64	0.8	0.96	30	1.71	0.65	0.82	0.98	28.4	1.99	0.67	0.85	1
	1150	33.4	1.19	0.64	0.81	0.97	32	1.44	0.65	0.83	0.99	30.4	1.7	0.67	0.86	1	28.8	1.98	0.69	0.88	1
71°F	550	29.8	1.23	0.43	0.53	0.63	28.6	1.47	0.43	0.54	0.64	27.4	1.72	0.43	0.54	0.65	26.2	2	0.44	0.55	0.66
	1050	34.8	1.18	0.46	0.62	0.76	33.2	1.43	0.47	0.62	0.78	31.6	1.7	0.47	0.64	0.8	30	1.97	0.48	0.66	0.83
	1150	35.2	1.17	0.47	0.63	0.79	33.6	1.43	0.47	0.64	0.81	32.2	1.69	0.48	0.66	0.83	30.4	1.97	0.49	0.68	0.86

4SCU20LX148P-1 - BCE4M48S - (MINIMUM CAPACITY)																					
Entering Wet Bulb Temperature	Total Air Volume	Outdoor Air Temperature Entering Outdoor Coil																			
		75°F					85°F					95°F					105°F				
		Total Cool Cap.	Comp Motor Input	Sensible to Total Ratio (S/T)			Total Cool Cap.	Comp Motor Input	Sensible to Total Ratio (S/T)			Total Cool Cap.	Comp Motor Input	Sensible to Total Ratio (S/T)			Total Cool Cap.	Comp Motor Input	Sensible to Total Ratio (S/T)		
				Dry Bulb					Dry Bulb					Dry Bulb					Dry Bulb		
		cfm	kBtuh	kW	75°F	80°F	85°F	kBtuh	kW	75°F	80°F	85°F	kBtuh	kW	75°F	80°F	85°F	kBtuh	kW	75°F	80°F
59°F	400	17.6	0.8	0.83	0.95	1	16.8	0.99	0.85	0.97	1	16.2	1.19	0.86	0.99	1	15.4	1.39	0.88	1	1
	830	22.6	0.74	1	1	1	21.8	0.94	1	1	1	20.8	1.15	1	1	1	19.8	1.36	1	1	1
	865	22.8	0.73	1	1	1	22	0.94	1	1	1	21	1.15	1	1	1	20	1.36	1	1	1
63°F	400	18.7	0.79	0.69	0.8	0.91	17.9	0.98	0.7	0.81	0.93	17.2	1.18	0.71	0.83	0.95	16.3	1.39	0.72	0.85	0.97
	830	22.6	0.74	0.85	1	1	21.8	0.94	0.87	1	1	20.8	1.15	0.89	1	1	19.8	1.36	0.92	1	1
	865	22.8	0.73	0.87	1	1	22	0.94	0.89	1	1	21	1.15	0.91	1	1	20	1.36	0.94	1	1
67°F	400	19.9	0.77	0.55	0.66	0.76	19.1	0.97	0.56	0.67	0.78	18.3	1.17	0.56	0.68	0.79	17.4	1.38	0.57	0.69	0.81
	830	23.8	0.72	0.65	0.83	0.98	22.6	0.93	0.67	0.85	1	21.6	1.14	0.69	0.88	1	20.2	1.36	0.69	0.9	1
	865	23.8	0.72	0.66	0.84	1	22.8	0.93	0.67	0.87	1	21.6	1.14	0.7	0.89	1	20.4	1.36	0.7	0.92	1
71°F	400	21	0.76	0.43	0.53	0.63	20.2	0.96	0.43	0.54	0.64	19.3	1.16	0.43	0.55	0.65	18.4	1.38	0.44	0.55	0.67
	830	25	0.7	0.47	0.63	0.8	24	0.91	0.48	0.66	0.82	22.8	1.13	0.48	0.67	0.85	21.6	1.35	0.49	0.7	0.87
	865	25.2	0.69	0.47	0.65	0.81	24.2	0.91	0.49	0.67	0.84	23	1.13	0.49	0.68	0.87	21.8	1.35	0.49	0.69	0.89

# COOLING PERFORMANCE EXTENDED RATINGS

4SCU20LX160P-1 - BCE4M60S - (MAXIMUM CAPACITY)																					
Entering Wet Bulb Temperature	Total Air Volume	Outdoor Air Temperature Entering Outdoor Coil																			
		85°F					95°F					105°F					115°F				
		Total Cool Cap.	Comp Motor Input	Sensible to Total Ratio (S/T)			Total Cool Cap.	Comp Motor Input	Sensible to Total Ratio (S/T)			Total Cool Cap.	Comp Motor Input	Sensible to Total Ratio (S/T)			Total Cool Cap.	Comp Motor Input	Sensible to Total Ratio (S/T)		
				Dry Bulb					Dry Bulb					Dry Bulb					Dry Bulb		
		cfm	kBtuh	kW	75°F	80°F	85°F	kBtuh	kW	75°F	80°F	85°F	kBtuh	kW	75°F	80°F	85°F	kBtuh	kW	75°F	80°F
59°F	1070	48	3.19	0.82	0.93	1	46.5	3.62	0.83	0.94	1	44.5	4.12	0.84	0.96	1	42.5	4.74	0.86	0.98	1
	1825	56.5	3.19	0.94	1	1	54.5	3.62	0.96	1	1	52.5	4.13	0.98	1	1	50	4.78	1	1	1
	1900	57	3.19	0.95	1	1	55	3.62	0.97	1	1	53	4.15	0.99	1	1	51	4.79	1	1	1
63°F	1070	51	3.19	0.68	0.78	0.89	49	3.62	0.69	0.8	0.9	47	4.14	0.7	0.81	0.92	45	4.76	0.71	0.83	0.94
	1825	58	3.19	0.77	0.91	1	56	3.62	0.78	0.93	1	53.5	4.14	0.8	0.95	1	51	4.78	0.81	0.97	1
	1900	58.5	3.18	0.78	0.92	1	56.5	3.62	0.79	0.94	1	54	4.15	0.81	0.96	1	51.5	4.79	0.83	0.98	1
67°F	1070	54	3.18	0.55	0.65	0.75	52	3.62	0.56	0.66	0.76	50	4.14	0.56	0.67	0.78	47.5	4.76	0.57	0.68	0.79
	1825	61	3.18	0.61	0.74	0.88	58.5	3.62	0.61	0.76	0.9	56	4.15	0.62	0.77	0.92	53.5	4.8	0.63	0.79	0.94
	1900	61.5	3.18	0.61	0.75	0.89	59	3.62	0.62	0.77	0.91	57	4.15	0.63	0.78	0.93	54	4.8	0.64	0.8	0.96
71°F	1070	56.5	3.19	0.44	0.53	0.63	54.5	3.62	0.43	0.54	0.63	52.5	4.14	0.44	0.54	0.64	50	4.78	0.44	0.55	0.65
	1825	64.5	3.18	0.46	0.59	0.72	62	3.62	0.46	0.6	0.73	59	4.16	0.46	0.61	0.75	56.5	4.81	0.47	0.62	0.77
	1900	65	3.18	0.46	0.6	0.73	62	3.62	0.46	0.6	0.74	59.5	4.16	0.46	0.62	0.76	57	4.82	0.47	0.63	0.78

4SCU20LX160P-1 - BCE4M60S - (INTERMEDIATE CAPACITY)																					
Entering Wet Bulb Temperature	Total Air Volume	Outdoor Air Temperature Entering Outdoor Coil																			
		75°F					85°F					95°F					105°F				
		Total	Comp	Sensible to Total			Total	Comp	Sensible to Total			Total	Comp	Sensible to Total			Total	Comp	Sensible to Total		
		Cool	Motor	Ratio (S/T)			Cool	Motor	Ratio (S/T)			Cool	Motor	Ratio (S/T)			Cool	Motor	Ratio (S/T)		
		Cap.	Input	Dry Bulb			Cap.	Input	Dry Bulb			Cap.	Input	Dry Bulb			Cap.	Input	Dry Bulb		
cfm	kBtuh	kW	75°F	80°F	85°F	kBtuh	kW	75°F	80°F	85°F	kBtuh	kW	75°F	80°F	85°F	kBtuh	kW	75°F	80°F	85°F	
59°F	735	32.4	1.48	0.83	0.95	1	31.2	1.78	0.84	0.96	1	30	2.08	0.86	0.98	1	28.6	2.42	0.88	1	1
	1135	37.4	1.44	0.94	1	1	36	1.74	0.96	1	1	34.6	2.04	0.98	1	1	33.2	2.38	1	1	1
	1400	40	1.42	1	1	1	38.5	1.72	1	1	1	37	2.03	1	1	1	35.2	2.36	1	1	1
63°F	735	34.4	1.47	0.69	0.8	0.9	33	1.77	0.69	0.81	0.92	31.6	2.06	0.7	0.82	0.94	30.2	2.4	0.72	0.84	0.96
	1135	38.5	1.43	0.76	0.91	1	37	1.74	0.78	0.92	1	35.2	2.04	0.79	0.95	1	33.6	2.37	0.81	0.97	1
	1400	40.5	1.41	0.81	0.97	1	38.5	1.72	0.83	0.99	1	37	2.03	0.85	1	1	35.2	2.36	0.87	1	1
67°F	735	36.4	1.45	0.56	0.66	0.76	35	1.75	0.56	0.67	0.77	33.6	2.06	0.57	0.68	0.79	32	2.39	0.57	0.69	0.81
	1135	40.5	1.41	0.6	0.74	0.87	39	1.71	0.61	0.75	0.89	37.2	2.02	0.62	0.76	0.91	35.6	2.36	0.63	0.79	0.94
	1400	42.5	1.39	0.63	0.79	0.94	40.5	1.7	0.64	0.81	0.96	39	2.01	0.65	0.82	0.98	37	2.34	0.67	0.85	1
71°F	735	38.5	1.43	0.44	0.54	0.63	36.8	1.73	0.44	0.54	0.64	35.4	2.04	0.44	0.55	0.65	33.8	2.37	0.44	0.55	0.66
	1135	43	1.39	0.45	0.58	0.71	41	1.69	0.46	0.59	0.73	39.5	2	0.46	0.6	0.74	37.4	2.34	0.47	0.61	0.76
	1400	45	1.37	0.47	0.62	0.77	43	1.67	0.47	0.63	0.78	41	1.98	0.48	0.64	0.8	39	2.31	0.48	0.66	0.82

4SCU20LX160P-1 - BCE4M60S - (MINIMUM CAPACITY)																					
Entering Wet Bulb Temperature	Total Air Volume	Outdoor Air Temperature Entering Outdoor Coil																			
		75°F					85°F					95°F					105°F				
		Total	Comp	Sensible to Total			Total	Comp	Sensible to Total			Total	Comp	Sensible to Total			Total	Comp	Sensible to Total		
		Cool	Motor	Ratio (S/T)			Cool	Motor	Ratio (S/T)			Cool	Motor	Ratio (S/T)			Cool	Motor	Ratio (S/T)		
		Cap.	Input	Dry Bulb			Cap.	Input	Dry Bulb			Cap.	Input	Dry Bulb			Cap.	Input	Dry Bulb		
cfm	kBtuh	kW	75°F	80°F	85°F	kBtuh	kW	75°F	80°F	85°F	kBtuh	kW	75°F	80°F	85°F	kBtuh	kW	75°F	80°F	85°F	
59°F	580	23	0.87	0.87	1	1	22.2	1.08	0.89	1	1	21.2	1.32	0.91	1	1	20.2	1.56	0.94	1	1
	890	26.8	0.85	1	1	1	25.6	1.08	1	1	1	24.6	1.33	1	1	1	23.4	1.58	1	1	1
	1100	28.6	0.84	1	1	1	27.2	1.09	1	1	1	26	1.34	1	1	1	24.8	1.6	1	1	1
63°F	580	24.4	0.86	0.71	0.84	0.96	23.2	1.08	0.73	0.86	0.98	22.2	1.32	0.74	0.88	1	21	1.57	0.76	0.9	1
	890	27	0.85	0.81	0.97	1	25.8	1.08	0.83	0.99	1	24.6	1.33	0.85	1	1	23.4	1.58	0.88	1	1
	1100	28.6	0.84	0.87	1	1	27.4	1.09	0.9	1	1	26	1.34	0.92	1	1	24.8	1.6	0.95	1	1
67°F	580	25.8	0.85	0.57	0.69	0.8	24.6	1.08	0.58	0.7	0.82	23.4	1.32	0.59	0.72	0.84	22.2	1.57	0.6	0.73	0.86
	890	28.6	0.84	0.63	0.79	0.94	27.2	1.08	0.64	0.8	0.96	25.8	1.34	0.65	0.83	0.99	24.4	1.59	0.67	0.85	1
	1100	29.8	0.84	0.67	0.85	1	28.4	1.09	0.68	0.87	1	26.8	1.35	0.7	0.9	1	25.2	1.6	0.72	0.93	1
71°F	580	27.2	0.85	0.44	0.55	0.66	26	1.08	0.44	0.56	0.68	24.8	1.33	0.44	0.57	0.69	23.4	1.58	0.45	0.58	0.71
	890	30.2	0.84	0.46	0.61	0.76	28.8	1.09	0.47	0.63	0.78	27.2	1.35	0.47	0.64	0.8	25.8	1.61	0.48	0.66	0.83
	1100	31.4	0.84	0.48	0.66	0.83	29.8	1.1	0.49	0.67	0.85	28.2	1.36	0.49	0.69	0.88	26.8	1.62	0.5	0.71	0.91

**ACCESSORIES**

Description	Where Used	Kit Number
TXV Kit	4SCU20LX124	H4TXV01
	4SCU20LX136	H4TXV02
	4SCU20LX148 - 4SCU20LX160	H4TXV03
Freezestat	3/8 tubing	93G35
Crankcase Heater	All models	Factory Installed
Sound Cover	All models	Factory Installed
Loss of Charge Kit	All models	Factory Installed
Comfort Sync™ Wi-Fi Thermostat	All models	1.841197
Comfort Sync™ Zoning Controller	All models	1.851399
Comfort Sync™ In-Zone Sensor	All models	1.851400
Discharge Temperature Sensor	All models	88K38



1-800-448-5872

All specifications and illustrations subject to change without notice and without incurring obligations.